



# 1.3M HD CAMERA

## CS-45XXMT / MA



- HD
- WDR color CMOS
- Metal case
- Waterproof (IP69K)
- Vibration test (30G)
- Compact size
- Various viewing angle
- Various bracket

### Resolution

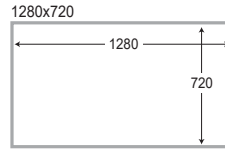

### Parking Line (Option)

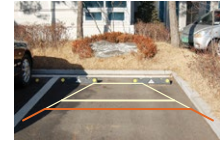

WDR Infrared rearview camera has wide visual field and prevent accident in the rear of vehicle by realtime clean image even night.

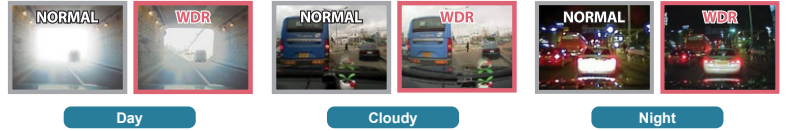

## MODEL NAME & VIEW ANGLE

 <b>CS-4504MT/MA</b> 60(H) / 35(V) / 69(D)	 <b>CS-4509MT/MA</b> 89(H) / 52(V) / 103(D)	 <b>CS-4512MT/MA</b> 118(H) / 67(V) / 137(D)	 <b>CS-4515MT/MA</b> 154(H) / 87(V) / 177(D)	 <b>CS-4518MT/MA</b> 196(H) / 124(V) / 232(D)
--	---	--	--	---

## DIMENSIONS & CABLE

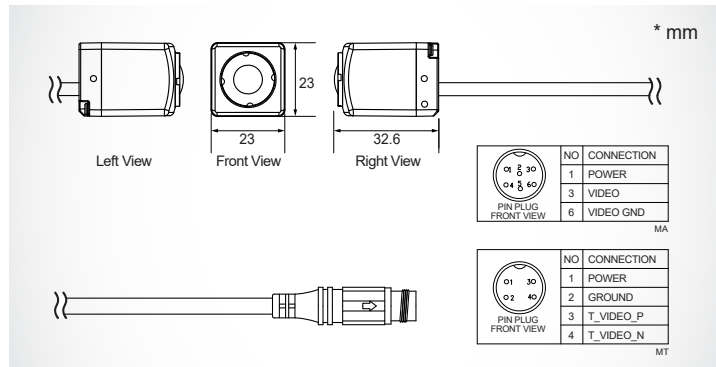

## SPECIFICATION

IMAGE DEVICE	1.3M WDR SENSOR 1/3"	
	IMAGE PIXEL SIZE	3.75 $\mu$ m (H) x 3.75 $\mu$ m (V)
RECORDING PIXEL	1,280(H) x 720(V) 1.2MPixel	
SIGNAL FORMAT	HD	
ASPECT RATIO	16:9	
FRAME RATE	30fps	
SCAN MODE	Progressive	
TV SYSTEM	NTSC TV SYSTEM	
IMAGE FREQUENCY	HORIZONTALITY	15.734KHz
	VERTICAL	59.94Hz
VIDEO OUT	HD video-out	
HORIZONTAL RESOLUTION	1000 TV Lines	
S/N RATIO	More Than 50dB (AGC OFF)	
WHITE BALANCE	Auto	
OUTPUT	VIDEO PORTS	(MT)Exclusive 4 pin connector (MA)Exclusive 6 pin connector
	VIDEO TYPE	MIRROR OR NORMAL
MIC	X	
IR LED / PHOTO SENSOR	X	
VIEW ANGLE	CS-4504MT/MA	60(H) / 35(V) / 69(D)
	CS-4509MT/MA	89(H) / 52(V) / 103(D)
	CS-4512MT/MA	118(H) / 67(V) / 137(D)
	CS-4515MT/MA	154(H) / 87(V) / 177(D)
	CS-4518MT/MA	196(H) / 124 (V) / 232(D)
MIN. ILLUMINATION	0.1 Lux	
INPUT VOLTAGE	DC 5-24V (MAX 30V)	
OPERATING TEMPERATURE	-20 $^{\circ}$ C ~ 70 $^{\circ}$ C	
STORAGE TEMPERATURE	-30 $^{\circ}$ C ~ 80 $^{\circ}$ C	
WATERPROOF	IP69K	
DIMENSION	23.0(W) x 23.0(H) x 32.6(D)mm (w/o Bracket)	
WEIGHT	65g (w/o bracket)	
CABLE LENGTH	0.5m	
BOX CONTENTS	BRACKET - SUNVISOR	BRACKET : O
	SCREWS SET	O
	EXTENSION CABLE	Option
	MANUAL	O

## BRACKET TYPE

