



HD CAMERA

CS-20XXMT / MA



- HD
- WDR color CMOS
- Metal case
- Waterproof (IP69K)
- 6 pcs of IR LEDs for night
- Photo sensor
- Compact size
- Various viewing angle

Resolution

1280x720

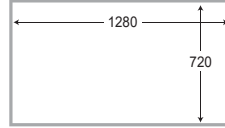

IR LEDs for night



Parking Line (Option)



WDR Infrared rearview camera has wide visual field and prevent accident in the rear of vehicle by realtime clean image even night.



MODEL NAME & VIEW ANGLE

 CS-2004MT/MA 60(H) / 35(V) / 69(D)	 CS-2009MT/MA 89(H) / 52(V) / 103(D)	 CS-2012MT/MA 118(H) / 67(V) / 137(D)	 CS-2015MT/MA 154(H) / 87(V) / 177(D)	 CS-2018MT/MA 192(H) / 122(V) / 210(D)
--	---	--	--	---

DIMENSIONS & CABLE

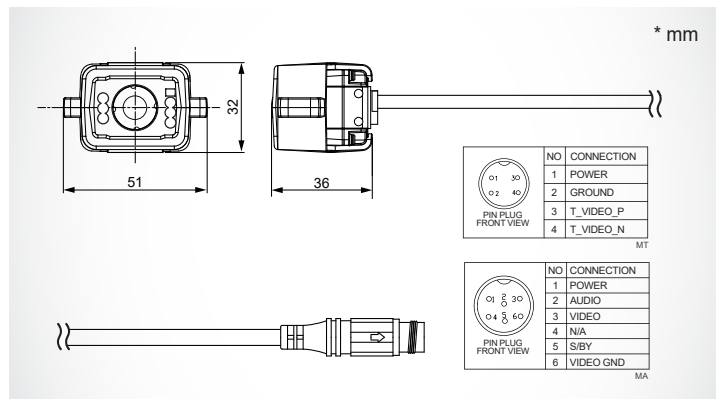

SPECIFICATION

IMAGE DEVICE	IMAGE DEVICE	1.3M WDR SENSOR 1/3"		
	IMAGE PIXEL SIZE	3.75μm (H) x 3.75μm (V)		
	RECORDING PIXEL	1,280(H) x 720(V) 1.2MPixel		
	SIGNAL FORMAT	HD		
	ASPECT RATIO	16:9		
	FRAME RATE	30fps		
	SCAN MODE	Progressive		
	TV SYSTEM	NTSC TV SYSTEM		
	IMAGE FREQUENCY	HORIZONTALITY	15.734KHz	
		VERTICAL	59.94Hz	
	VIDEO OUT	HD video-out		
	HORIZONTAL RESOLUTION	1000 TV Lines		
	S/N RATIO	More Than 50dB (AGC OFF)		
	WHITE BALANCE	Auto		
	OUTPUT	VIDEO PORTS	Exclusive 4 pin connector	Exclusive 6 pin connector
VIDEO TYPE		MIRROR OR NORMAL		
MIC	X			
IR LED / PHOTO SENSOR	IR 6ea / Photo sensor 1ea / 850nm (RED)			
VIEW ANGLE	CS-2004MT/MA	60(H) / 35(V) / 69(D)		
	CS-2009MT/MA	90(H) / 52(V) / 103(D)		
	CS-2012MT/MA	118(H) / 67(V) / 137(D)		
	CS-2015MT/MA	154(H) / 87(V) / 177(D)		
	CS-2018MT/MA	192(H) / 122 (V) / 210(D)		
MIN. ILLUMINATION	IR ON 0Lux			
INPUT VOLTAGE	DC 12-24V (MAX 30V)			
OPERATING TEMPERATURE	-20℃ ~ 70℃			
STORAGE TEMPERATURE	-30℃ ~ 80℃			
WATERPROOF	IP69K			
DIMENSION	51(W) x 32(H) x 36(D)mm (w/o Bracket)			
WEIGHT	85g (W) (w/o Bracket)			
CABLE LENGTH	1.0m			
BOX CONTENTS	BRACKET · SUNVISOR	O		
	SCREWS SET	O		
	EXTENSION CABLE	Option		
	MANUAL	O		

CABLE CONNECTION

