



# HD (CVBS) CAMERA

## CS-20XXM



- WDR color CMOS
- Metal case
- Waterproof (IP69K)
- 6 pcs of IR LEDs for night
- Photo sensor
- Compact size
- Various viewing angle
- Audio Built-in

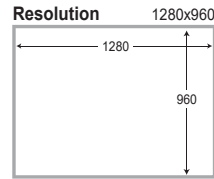

**WDR** Infrared rearview camera has wide visual field and prevent accident in the rear of vehicle by realtime clean image even night.



## MODEL NAME & VIEW ANGLE

<p><b>CS-2004M</b> 53(H) / 38(V) / 67(D)</p>	<p><b>CS-2009M</b> 82(H) / 61(V) / 104(D)</p>	<p><b>CS-2012M</b> 112(H) / 84(V) / 140(D)</p>	<p><b>CS-2015M</b> 138(H) / 103(V) / 169(D)</p>	<p><b>CS-2018M</b> 184(H) / 147(V) / 210(D)</p>
--	---	--	---	---

## DIMENSIONS & CABLE

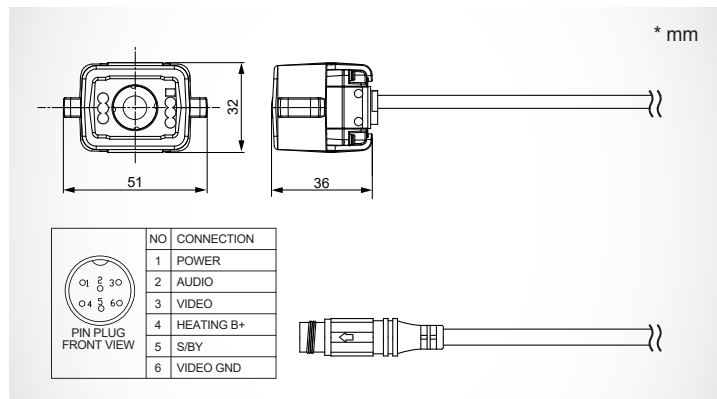

## SPECIFICATION

DEVICE	IMAGE DEVICE	1.3M WDR SENSOR 1/3.2"		
	IMAGE PIXEL SIZE	3.5 $\mu$ m (H) x 3.5 $\mu$ m (V)		
	RECORDING PIXEL	1,280(H) x 960(V) 1.23M Pixel		
	SIGNAL FORMAT	CVBS		
	ASPECT RATIO	4:3		
	FRAME RATE	60fps		
	SCAN MODE	Interlace		
	TV SYSTEM	NTSC TV SYSTEM	PAL TV SYSTEM	
	IMAGE FREQUENCY	HORIZONTALITY	15.734KHz	15.625KHz
		VERTICAL	59.94Hz	50Hz
	VIDEO OUT	Composite video-out		
	HORIZONTAL RESOLUTION	1000 TV Lines		
	S/N RATIO	More Than 50dB (AGC OFF)		
	WHITE BALANCE	Auto		
	OUTPUT	VIDEO PORTS	Exclusive 6 pin connector	
		VIDEO TYPE	MIRROR OR NORMAL	
	MIC	O		
	IR LED / PHOTO SENSOR	IR 6ea / Photo sensor 1ea / 850nm (RED)		
	VIEW ANGLE	CS-2004M	53(H) / 38(V) / 67(D)	
		CS-2009M	82(H) / 61(V) / 104(D)	
		CS-2012M	112(H) / 84(V) / 140(D)	
		CS-2015M	138(H) / 103(V) / 169(D)	
		CS-2018M	184(H) / 147(V) / 210(D)	
	MIN. ILLUMINATION	IR ON 0Lux		
	INPUT VOLTAGE	DC 12-24V (MAX 30V)		
	OPERATING TEMPERATURE	-20 $^{\circ}$ C ~ 70 $^{\circ}$ C		
	STORAGE TEMPERATURE	-30 $^{\circ}$ C ~ 80 $^{\circ}$ C		
	WATERPROOF	IP69K		
	DIMENSION	51(W) x 32(H) x 36(D)mm (w/o Bracket)		
	WEIGHT	85g (W) (w/o Bracket)		
	CABLE LENGTH	1.0m		
	BOX CONTENTS	BRACKET · SUNVISOR	O	
		SCREWS SET	O	
EXTENSION CABLE		Option		
MANUAL		O		

## CABLE CONNECTION

